

APPROACH TOWARDS DEVELOPMENT OF 350 MHZ BULK NIOBIUM SCRF CAVITIES FOR 10 MEV PROTOTYPING PHASE OF THE PROPOSED PROTON LINAC

A. M. Puntambekar[#], M. G. Karmarkar
Centre for Advanced Technology, CAT, Indore, INDIA

Abstract

In this paper we present the approach for the development of bulk niobium re-entrant type 350 MHz SC RF cavity. The work is a part of development of a 10 MeV prototyping phase of the proposed Proton LINAC (PPL) being pursued by Centre for Advanced Technology, Indore (India). 350 MHz Cavity has been designed using SUPERFISH and structural analysis has been done by ANSYS [1]. It is proposed to adopt the bulk niobium approach for double wall cavity. Various stages during development have been investigated that will include special infrastructure & systematic stage inspection & testing.

INTRODUCTION

For the low energy regime of the PPL (4.5 MeV to 100 MeV) it has been decided to pursue both SC & NC option. For the SC option Spoke and Re-Entrant type cavity are candidate options [2], [3]. To begin with we have done initial study for Re-entrant type of design. The RE cavity inner & outer vessels will be produced by deep drawing techniques followed by electron beam welding. The inner vessel will be made from high RRR Nb (>180) while the outer vessel will be made using low RRR Nb (~30). The transition metal joints required for the demountable flanges, which are to be welded to Nb ports will be a tried using explosion bonded Nb-SS sheets as well as by Vacuum brazing technique.

CAVITY FABRICATION

Fabrication of cavity involves various stages requiring close interaction between press shop, machine shop, EB welding, chemical cleaning and high pressure rinsing (HPR) station. Various stages for the complete cycle are: Deep drawing, weld joint, EB welding with intermediate cleaning, high temperature (HT) vacuum annealing, coarse tuning, leak check and lastly high pressure rinsing prior to final assembly in a clean room. Table -1 shows the main parameters of the single gap RE cavity. Fig-1& 2 shows the SUPERFISH and ANSYS model for the same respectively. Fig-3 shows the deformation of cavity under vacuum load with 2 bar helium pressure at operating temperature of 4.5 K. Fig-4 shows the engineering drawing of the cavity and fig-5 shows various stages of fabrication of outer and inner vessel.

350 MHz TM010 Cavity Freq = 349.839

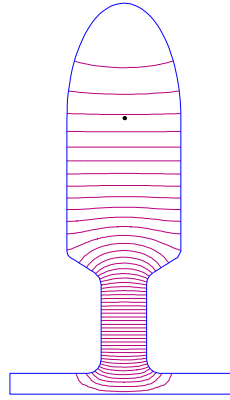

Fig-1

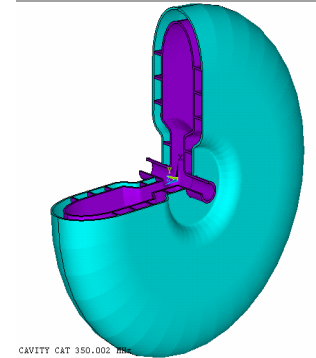

Fig-2

Table-1: Parameters of the 350 MHz re-entrant SC cavity

S No.	Parameters	
1.	Resonant frequency	350 MHz
2.	β	0.20
3.	Material	Nb
4.	E_0	1 MV/m
5.	Q_0	5.6×10^8
6.	Power dissipation ($E_0=1\text{MV/m}$)	544 mW
7.	Z sh (effective) (at design β)	$2.18 \times 10^5 \text{ M}\Omega/\text{m}$
8.	$B_{\text{max}} / E_{\text{max}}$	1.09 mT/(MV/m)
9.	E_{max}/E_0	5.2

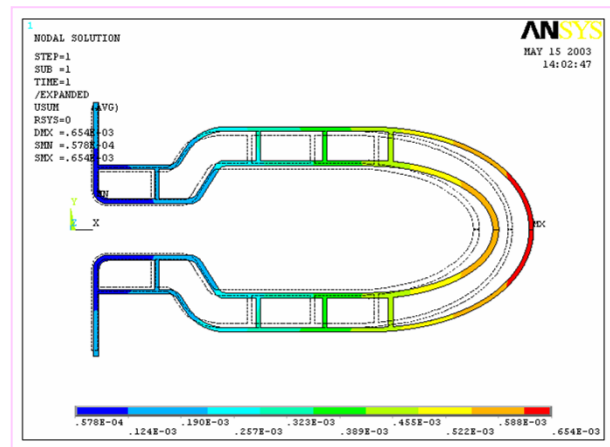

Fig-3

[#] avinash@cat.ernet.in

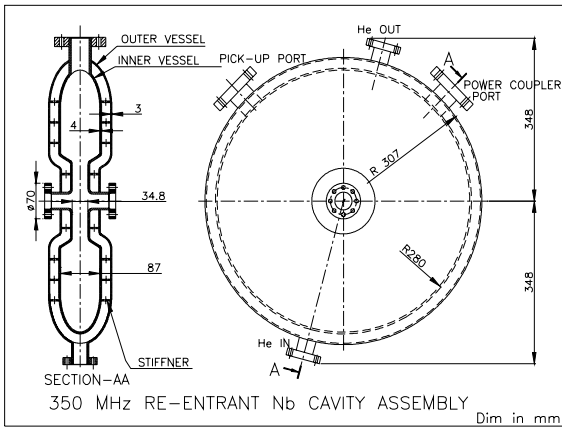

Fig-4

PROCESSING SCHEME

Considerable R&D efforts will be necessary to finalise the process and various parameters. Development of cavity fabrication is planned in two stages. [4],[5],[6]

A. Technological process investigation qualification:

- Material
 - Chemical composition, physical properties
 - Structural and surface condition
 - RRR (measurement with dedicated test set up)
- Forming
 - Forming tool material, size calibration
 - Checks on press form parts for contamination of surface after forming
- Weld Joint qualification
 - Joint design
 - EB weld parameter finalization using coupons.
- Transition joint
 - Joint mechanical strength
 - Ultrasonic inspection for flaw detection
 - Leak testing after thermal cycling
- Sealing
 - Metal wire seals & leak investigation with effect of thermal cycling
- Chemical Cleaning, HP rinsing, HT annealing process qualification.

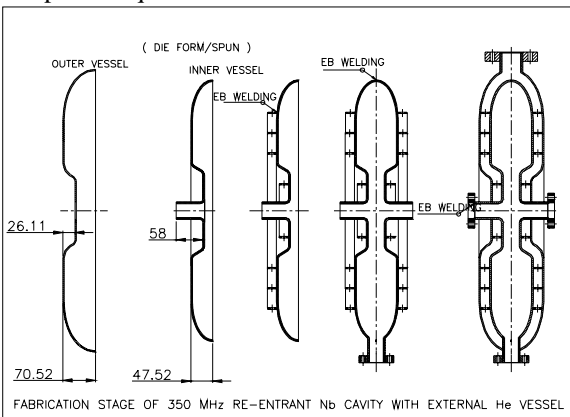
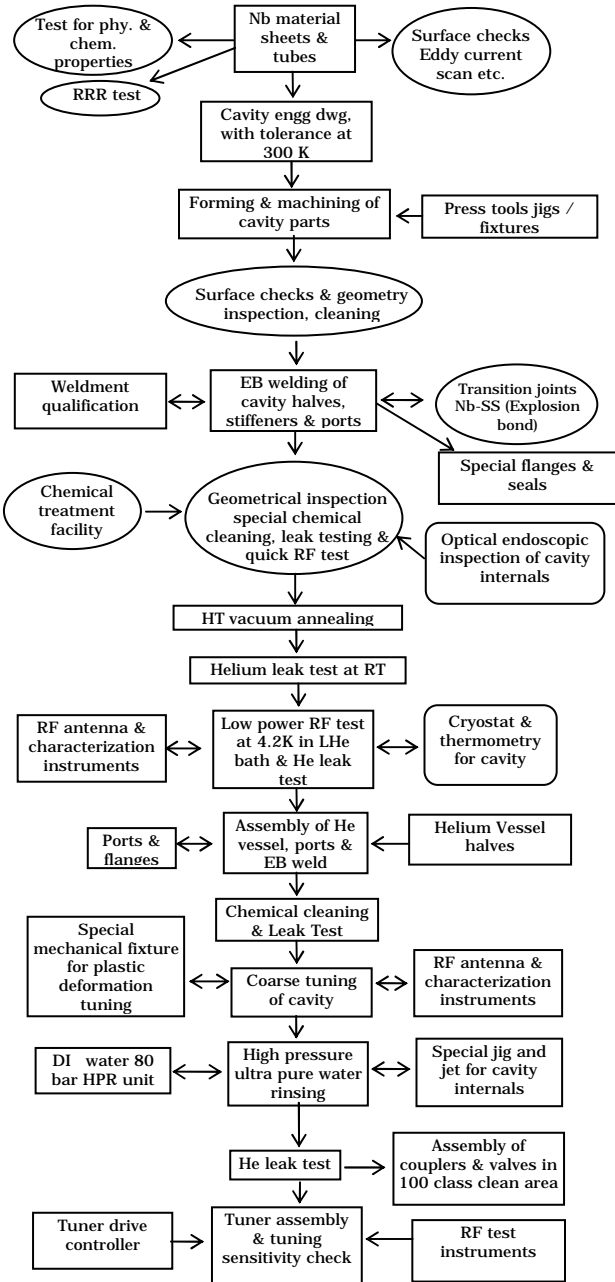

Fig5

A flow chart showing various stages of activities involved:



B. Cavity fabrication & stage inspection & testing

- Two halves forming, trimming & pullouts for ports
 - Geometrical inspection
 - Surface checking
 - Weld fitment
 - Chemical cleaning
- EB welding of inner vessel
- Leak test & initial RF test
- Outer vessel welding and leak test
- Coarse tuning with plastic deformation
- HT annealing and leak tests
- Chemical cleaning
- HP Rinsing & leak tests

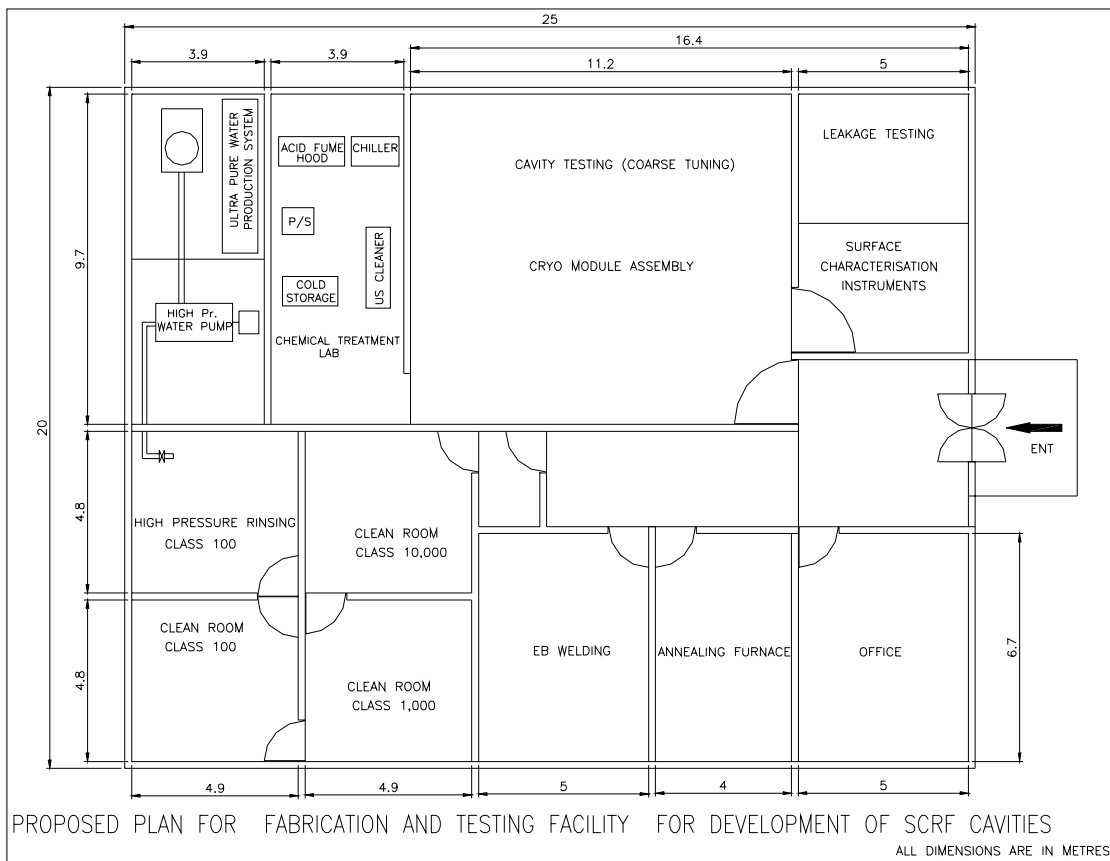

Fig-6

- Clean room assembly
- Full power RF Test at 4.2K

SPECIAL INFRASTRUCTURE

Cavity fabrication requires variety of special infrastructure. We have estimated initial specifications for the major facilities as below:

EB Welding machine: Electron Gun Beam Power -15 kW, Operating Voltage 20-60 kV, Beam Current - 0-250 mA. High temperature vacuum Annealing Furnace: Hot zone size = \varnothing 1000 mm x 1250 mm (H), Operating temperature = 400 - 1300 °C with controls, Cooling / heating cycles, Vacuum level at 1200 °C = 1×10^{-5} Torr. HPR station: Ultra pure DI water at 80-100 bars pressure & 5-10 lpm with suitable fixture / jets for cavity internal cleaning. Chemical cleaning Degreasing with Ultra Sonic agitation, (with BCP facility) and clean room class 1000 & 100 of desired dimensions, cryostats for testing & cavities for 4.5K integrity. [7] Figure 6 shows the layout for the prototype fabrication and test facility.

CONCLUSION

The preliminary investigation and studies have paved the way to initiate the development of prototype fabrication of RE cavity and all related infrastructure.

ACKNOWLEDGEMENT

We acknowledge useful input & discussions with LINAC team at CAT and also Shri P N Prakash, R. Mehta of NSC Delhi and S. Calatroni, CERN.

REFERENCES

- [1] Preliminary technical report CAT/AP/MGK/03-01, June 2003 : 100 MeV High Power Proton Linac
- [2] Design of a Low- β , 2-Gap spoke resonator for the AAA project, F Krawczyk, at el SCRF 2001 workshop
- [3] RF testing of the TRASCO superconducting Re-entrant cavity for high intensity proton beams., A. Facco et al EPAC-2002.
- [4] Review of fabrication of Sc Cavity structure. V.Palmieri.
- [5] RF superconductivity for Accelerators, Hasan Padamsee, J. Knobloch, Tom Heyes, John Wiley & Sons
- [6] Niobium SC Resonator design, fabrication & testing. P.Prakash et al., NSC, NewDelhi. INPAC-03, CAT, India.
- [7] Approach towards establishing cryogenic test facility for SCRF cavities of 10 MeV Proton Linac. P. Khare, P.K. Kush, M. G. Karmarkar, in this workshop.